

# ART DISPLAY CASE

ONE MAIN STREET  
PROFESSIONAL PLAZA  
AUBURN WASHINGTON 98002

**J. DORBRITZ AIA**  
ARCHITECTURE & PLANNING

800 Fernwood Pacific  
Topanga, California 90280  
310 455 1264  
310 455 1837 fax  
dorbritz@verizon.net

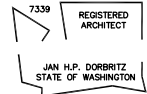

AUBURN  
PROFESSIONAL PLAZA  
L.L.C.

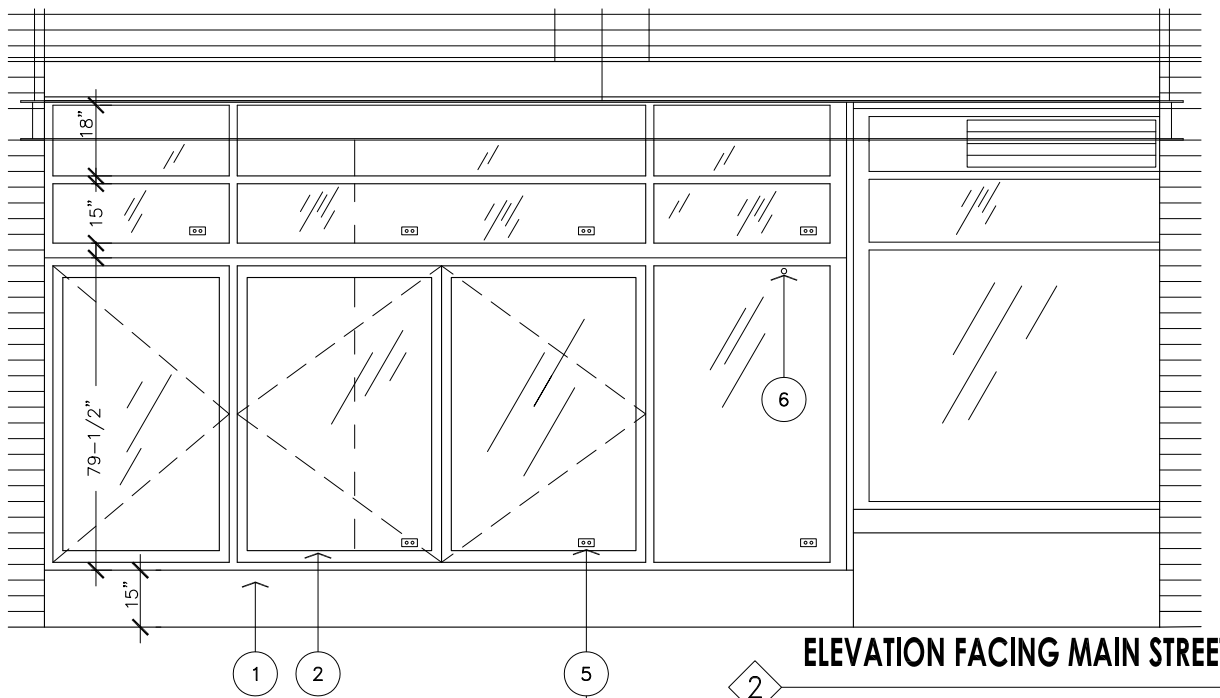

**ELEVATION FACING MAIN STREET**

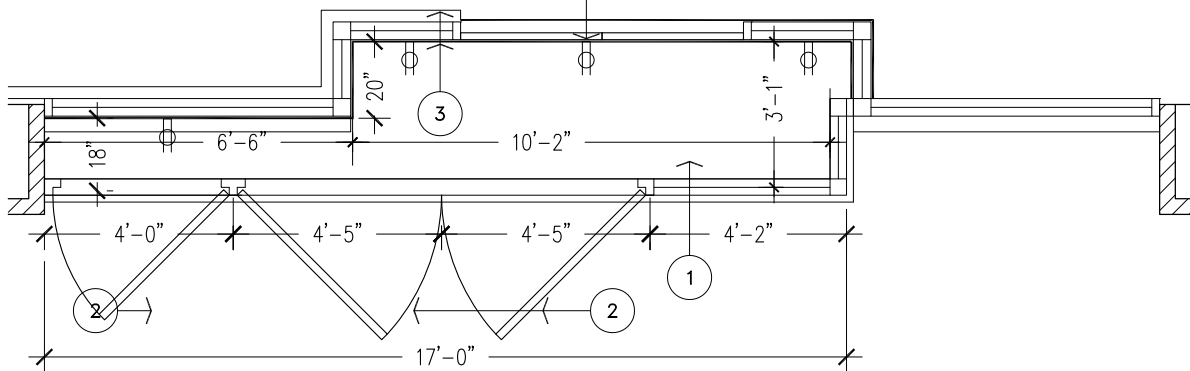

**PLAN AT ART DISPLAY CASE**

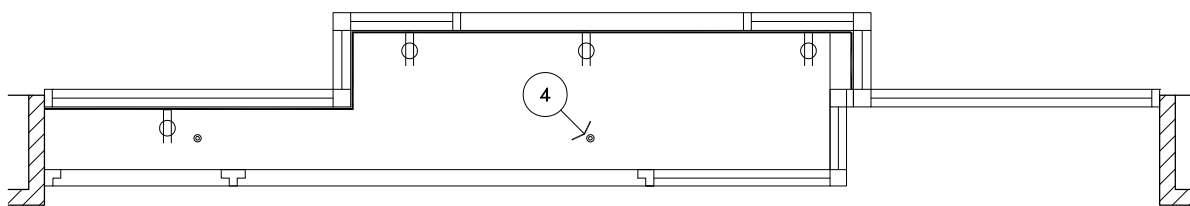

**CEILING AT ART DISPLAY CASE**

## KEY NOTES

- 1 STRUCTURAL PLATFORM AT APPROX. 15" ABOVE SIDEWALK FINISH.
- 2 STOREFRONT WITH FIXED AND OPEN ABLE (SWINGING) SECTIONS WITH CONCEALED LOCKS AND CRAB BARS.
- 3 TRANSPARENT GLAZING SECTIONS WITH GYPSUM BOARD ON INSIDE OF DISPLAY CASE AND ON INSIDE OF TENANT SPACE.
- 4 FIRE SPRINKLER HEAD, TYP (SEE CEILING PLAN).
- 5 POWER OUTLET, TYPICAL.
- 6 VENT (MINOR AIR EXCHANGE).

Issue: \_\_\_\_\_

Revisions  
11 / 30 / 15  
10 / 12 / 16

Sheet Title:  
**ART DISPLAY CASE  
PLAN, ELEVATION,  
NOTES**

Scale: N.A.

Sheet Number:  
**T-ART**

Date: 10 / 12 / 16

Project Number: 06-03-162

All drawings and written material appearing herein constitute the work product of the architect and may not be used or disclosed without prior written consent of the Architect.  
© 2016 Dorbritz Architects